

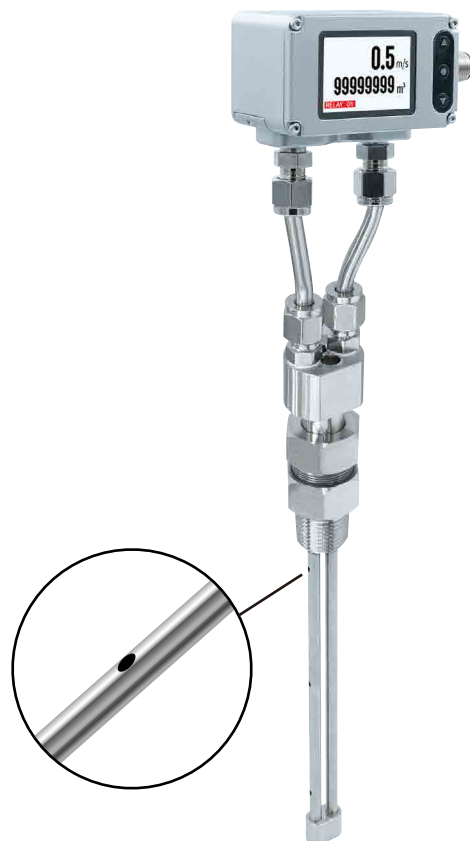

FDM06-P

Average Flow Thermal Mass Transmitter



| Features |

- High Sensitivity, Low Pressure Loss, Detects Minute Airflow Changes
- No Compensation Needed, Direct Flow Output
- Sizes 1"~ 40", Easy Installation
- $\pm 1.5\%$ F.S. Accuracy, 16 bar Pressure Resistance
- Analog, Relay, RS-485 Outputs
- Suitable for various types of gases (N_2 , Ar, CO_2 , etc.)

| Applications |

Compressed Air System Management / Optimization of Air Compressors & Pneumatic Equipment Efficiency / Air Dryer Flow Control / Process Gas Consumption Monitoring (N_2 , Ar, CO_2 , etc.) / Pipeline Leak Detection & Alerts / HVAC Duct Monitoring / Smart Manufacturing Energy Management / Cleanroom Airflow Monitoring / Biotech & Pharmaceutical Gas Supply Stability Monitoring / Food Processing Gas Filling & Packaging Monitoring

| Specification |

Input

Sensor type	Hot-wire sensor
Turndown ratio	100 : 1
Measuring range	0 ... 60 m/s

Output

Output signal	4 ... 20 mA / 0 ... 10 V / Relay / RS-485
Signal connection	3-wire
Warm-up time	60 sec
Response time	$t_{90} \leq 6$ sec
Load resistance	Current output : $\leq 500 \Omega$ Voltage output : $\geq 10 K\Omega$

Communication

Communication methods & protocol	RS-485 Modbus RTU
RS-485 baud rate	9600、19200、38400、57600、115200 bps

Accuracy

Accuracy	0.5 ... 60 m/s : $\pm(1.5\% \text{ of mv} + 0.8 \text{ m/s})$
Temp. influence	0.2% / °C
Uncertainty of factory calibration	$\pm 1\%$

*The measurement range is defined at the standard condition(1013 mbar, 20°C).
*mv = measured value

Environmenta

Medium	Non-corrosion gas
Operating Temp. & Humid.	0 ... 50°C / 20 ... 90%RH(Non-condensing)
Storage Temp.	-20 ... +60°C
Operating pressure	16 bar

Electrical

Power supply	DC 24 V $\pm 10\%$
Current consumption	24 V : 110 mA
Relay capacity	Max current : 6 A Max voltage : DC 24 V (DC 36 V Max)
Electrical connection	M12 8P connector

Installation

Installation	PT 3/4" movable thread, PT 1/2" movable thread
--------------	--

Display

Display readout	0 ... 99999999 (Cumulative flow : 8-digit) 0 ... 99999 (Instantaneous flow : 5-digit)
Decimal point	Button
Sampling time	1 cycle/sec
Unit	m/s、ft/s、L/min、m ³ /min、m ³ /h、mL、L m ³ 、ft ³ 、inch ³ 、gal、uk gal
Response time adjustment range	0.5 ... 300 秒

Certification

Certification	CE
---------------	----

Protection

IP rating	IP65
Electrical protection	■ Reverse polarity ■ Over-voltag

Material

Housing	Aluminum alloy
Probe	SUS316

| Diagram |

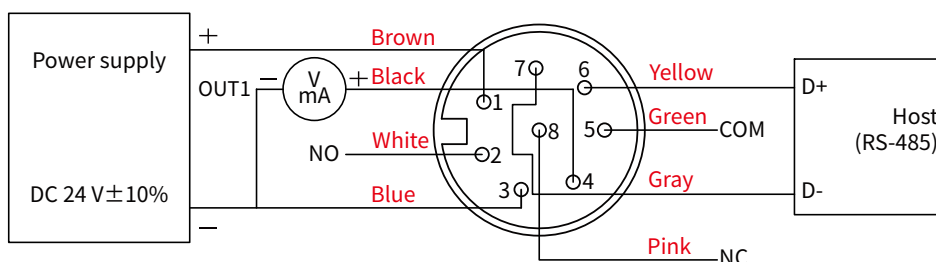

*Please make sure the product and the device which connect with RS-485 are on common ground, avoid damaged product.

| Wind Tunnel Calibration System |



The wind tunnel calibration system provides a stable and standardized environment for calibration, is not affected by external factors, and has an automated detection system to greatly improve calibration accuracy and reliability. It follows the operating standards of ISO/IEC 17025 and a calibration report can be purchased separately.

| Measurement Principle | Combining Pitot Tube and Thermal Mass Flow Sensing Technology

■ Pitot tube

Measures the pressure difference between the total pressure and the static pressure to calculate the fluid velocity. The difference between total pressure and static pressure is the dynamic pressure, which is caused by the fluid's velocity. Dynamic pressure is proportional to the square of the air velocity, thus allowing calculation of fluid velocity through the measured dynamic pressure.

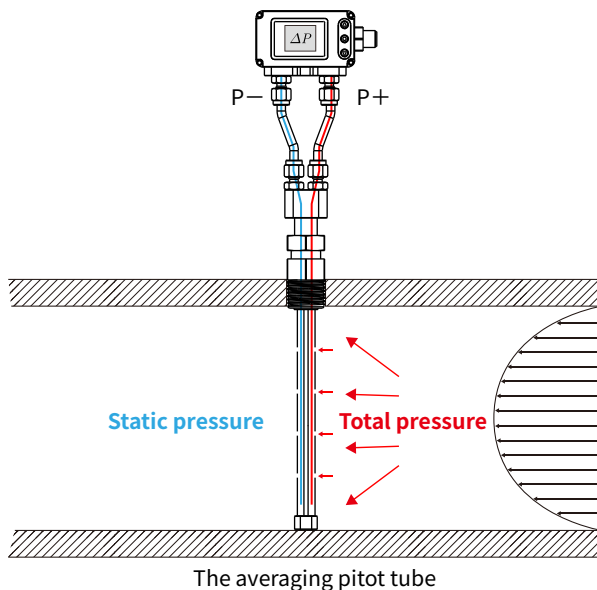

■ Formula

$$V = K \sqrt{\frac{2}{\rho} \Delta P}$$

$$Q_v = K \varepsilon A \sqrt{\frac{2}{\rho} \Delta P}$$

$$Q_m = Q_v \times \rho$$

V = Velocity

ΔP = Difference between total pressure and static pressure

ρ = Density

K = Calibration factor

Q_v = Volumetric flow rate

Q_m = Mass flow rate

ε = Inflation coefficient

A = Cross-sectional area

■ Hot-wire type differential pressure measurement

The FDM06-I adopts a hot-wire type differential pressure sensor combined with a Venturi tube. It calculates the flow rate by measuring the differential pressure at two points in the Venturi tube. Hot-wire type differential pressure measurement technology calculates the pressure difference by measuring the air flow rate. When there is a pressure difference between two measurement points, air flows from the high-pressure side to the low-pressure side through a channel inside the transmitter. The channel contains a heating element and two temperature sensors. By comparing the heating and temperature changes, the air flow rate can be precisely measured, which in turn allows the calculation of the pressure difference. This technology can detect extremely low air flow rates, making it possible to precisely measure small pressure differences. Additionally, hot-wire type measurement technology has the characteristic of low zero-point drift, meaning the transmitter can maintain a stable initial zero point even after prolonged use, ensuring measurement precision and reliability.

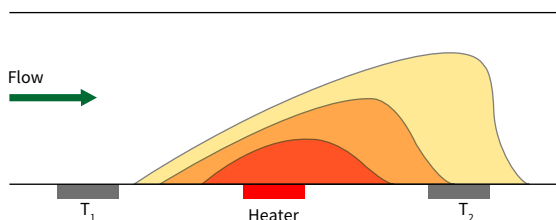

■ Formula

$$P = A + B \cdot V^n$$

P : Heating power

A : Power loss with no flow

V : Velocity

B : Fluid velocity

n : Velocity exponent

Dimension | Unit : mm

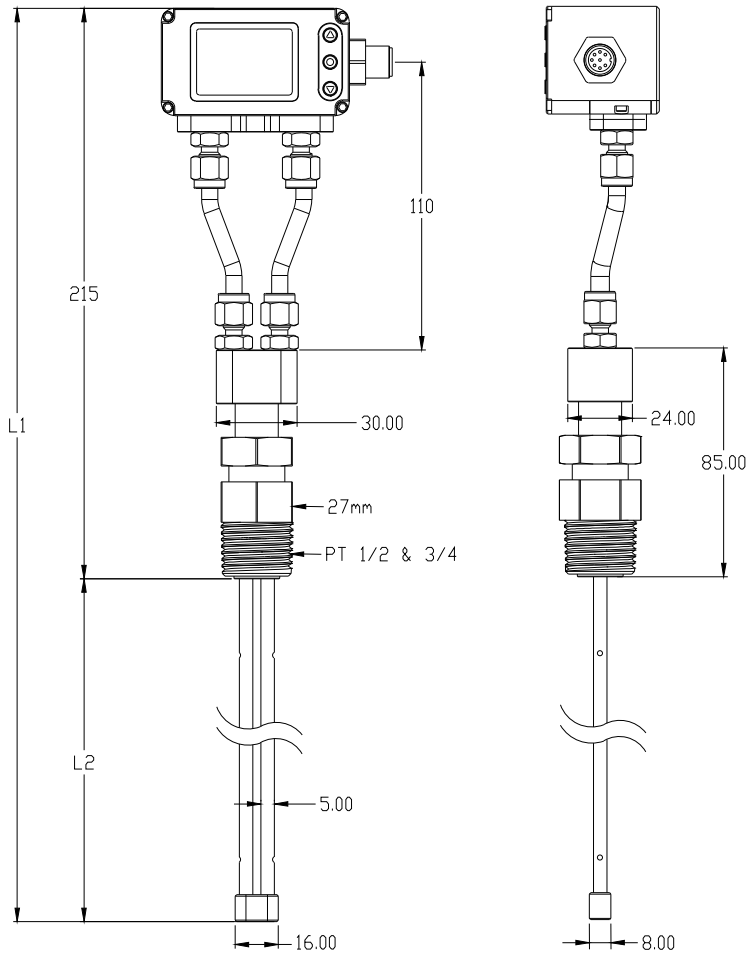
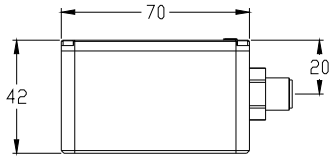

	L1	L2
DN25 (1")	240 mm	25 mm
DN50 (2")	265 mm	50 mm
DN100 (4")	315 mm	100 mm
DN150 (6")	365 mm	150 mm
DN200 (8")	415 mm	200 mm
DN250 (10")	465 mm	250 mm
DN300 (12")	515 mm	300 mm
DN450 (18")	665 mm	450 mm
DN600 (24")	815 mm	600 mm
DN800 (32")	1015 mm	800 mm
DN1000 (40")	1215 mm	1000 mm

Air Velocity / Volume Conversion Table |

*Airflow conversion is adjusted using PF (Profile Factor) values, typically measured on-site, with a recommended range of 0.7 to 1.

*The measurement range is defined at the standard condition(1013 mbar, 20°C).

ID of pipe	Air velocity inside pipe		
	20m/s	40m/s	60m/s
DN25 (1")	35.3 m ³ /h	35.3 m ³ /h	106 m ³ /h
DN50 (2")	141.4 m ³ /h	141.4 m ³ /h	424.1 m ³ /h
DN100 (4")	565.5 m ³ /h	565.5 m ³ /h	1696.5 m ³ /h
DN150 (6")	1272.3 m ³ /h	1272.3 m ³ /h	3817 m ³ /h
DN200 (8")	2262 m ³ /h	2262 m ³ /h	6785.9 m ³ /h
DN250 (10")	3534.3 m ³ /h	3534.3 m ³ /h	10602.9 m ³ /h
DN300 (12")	5089.4 m ³ /h	5089.4 m ³ /h	15268.2 m ³ /h
DN450 (18")	11451.1 m ³ /h	11451.1 m ³ /h	34353.4 m ³ /h
DN600 (24")	20357.6 m ³ /h	20357.6 m ³ /h	61072.7 m ³ /h
DN800 (32")	36191.2 m ³ /h	36191.2 m ³ /h	108573.7 m ³ /h
DN1000 (40")	56548.8 m ³ /h	56548.8 m ³ /h	169646.4 m ³ /h

| Ordering Guide |

FDM06 —	Connection P	Range 20	Output 2	Length 200	Movable thread R1	Display & Other A
	<p>P : Average Flow</p>	<p>20 : 20 m/s 40 : 40 m/s 60 : 60 m/s</p>	<p>2 : 4 ... 20 mA+RS-485+Relay 3 : 0 ... 10 V+RS-485+Relay</p>	<p>025 : 1" (25 mm) 050 : 2" (50 mm) 100 : 4" (100 mm) 150 : 6" (150 mm) 200 : 8" (200 mm) 250 : 10" (250 mm) 300 : 12" (300 mm) 450 : 18" (450 mm) 600 : 24" (600 mm) 800 : 32" (800 mm) 1000 : 40" (1000 mm)</p>	<p>R1 : 1/2"PT R2 : 3/4"PT</p>	<p>A: Flow Velocity B: Flow Rate C: Flow Velocity + Flow Rate W: Flow Rate + Totalized Flow</p>

| Additional Option Test Report | For more detailed information please contact us.

■ ILAC / TAF

YUDEN-TECH CO.,LTD. Calibration Laboratory - (ILAC / TAF) Test report.

(TAF accreditation : 3032, complying with ISO / IEC 17025) TAF has mutual recognition arrangement with ILAC MRA

Project	Measurand level or range
Air velocity transmitter	0.2 m/s ... 60 m/s

■ ISO 9001

Project	Measurand level or range
Air velocity / Air volume	Air velocity : ≤ 120 m/s
	Air volume : 0.5 m ³ /h ... 1000 m ³ /h